

Pump-out Station LS200W

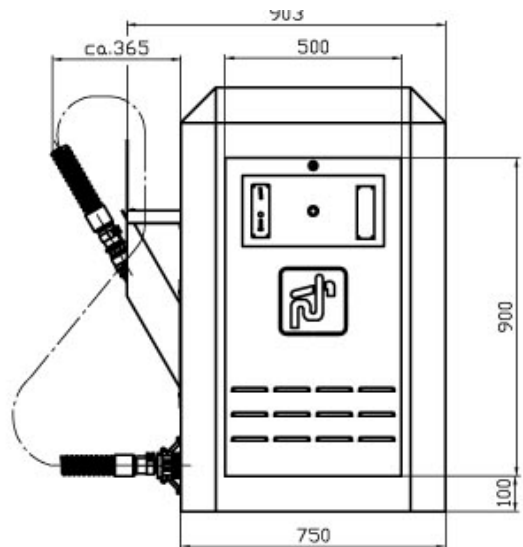

- High quality housing made of 316 stainless steel
- Self priming peristaltic pump, can run dry
- Integrated drip tray
- Easy to service and to maintenance due to the full removable door
- 15m high flexible Suction hose 1 1/2" (38mm)
- Pump-out Probe meets the european standard ISO 8099
- Different control options (coin, Token, Key or Start/Stop buttons)
- Self priming up to 9m high
- Voltage 400V available



Data:

Capacity	300l/min
Motor power:	3600W
Suction height max:	9m
Discharge length max:	200m
Pressure height max:	15m
Weight:	170 kg